

General Description

The MY9N90F is silicon N-channel Enhanced VDMOSFETS, obtained by the self-aligned planar Technology which reduce the conduction loss, improve switching performance and enhance the avalanche energy.



Features

V_{DSS}	900	V
I_D	9	A
$P_D(T_C=25\text{C})$	280	W
$R_{DS(ON)}(at\ V_{GS}=10V)$	1.05	Ω

Application

- High efficiency switch mode power supplies
- Power factor correction
- Electronic lamp ballast

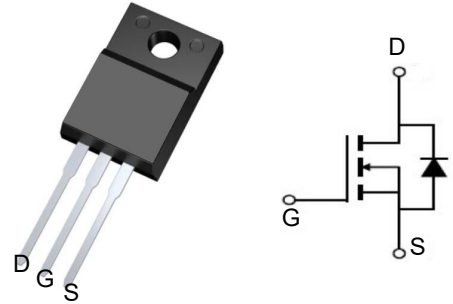

Package Marking and Ordering Information

Product ID	Pack	Marking	Qty(PCS)
MY9N90F	TO-220F	MY9N90F	1000

Absolute Maximum Ratings ($T_C=25\text{ }^\circ\text{C}$ unless otherwise noted)

Symbol	Parameters	Ratings	Unit
V_{DSS}	Drain-Source Voltage	800	V
V_{GS}	Gate-Source Voltage-Continuous	± 30	V
I_D	Drain Current-Continuous (Note 2)	9	A
I_{DM}	Drain Current-Single Plused (Note 1)	36	A
P_D	Power Dissipation (Note 2)	280	W
T_j	Max.Operating junction temperature	150	$^\circ\text{C/W}$

Electrical Characteristics (T_c=25 °C, unless otherwise noted)

Symbol	Parameters	Min	Typ	Max	Units	Conditions
Static Characteristics						
B _{VDSS}	Drain-Source Breakdown VoltageCurrent (Note 1)	900	--	--	mA	I _D =250μA V _{GS} =0V , T _J =25°C
V _{GS(th)}	Gate Threshold Voltage	2.0	--	4.0	V	V _{DS} =V _{GS} , I _D =250μA
R _{DS(on)}	Drain-Source On-Resistance	--	1.05	1.4	Ω	V _{GS} =10V , I _D =4.5A
I _{GSS}	Gate-Body Leakage Current	--	--	±100	nA	V _{GS} =±30V , V _{DS} =0
I _{DSS}	Zero Gate Voltage Drain Current	--	--	10	μA	V _{DS} =900V , V _{GS} =0
Switching Characteristics						
T _{d (on)}	Turn-On Delay Time	--	55	--	ns	V _{DS} =450V , I _D =9A, R _G =25Ω (Note 2)
T _r	Rise Time	--	130	--	ns	
T _{d (off)}	Turn-Off Delay Time	--	11	--	ns	
T _f	Fall Time	--	80	--	ns	
Q _g	Total Gate Charge	--	670	--	nC	V _{DS} =480, V _{GS} =10V I _D =9A (Note 2)
Q _{gs}	Gate-Source Charge	--	13.5	--	nC	
Q _{gd}	Gate-Drain Charge	--	27	--	nC	
Dynamic Characteristics						
C _{iss}	Input Capacitance	--	2780	--	pF	V _{DS} =25V , V _{GS} =0, f=1MHz
C _{oss}	Output Capacitance	--	228	--	pF	
C _{rss}	Reverse Transfer Capacitance	--	28	--	pF	
I _S	Continuous Drain-Source Diode ForwardCurrent (Note 2)	--	--	9	A	
V _{SD}	Diode Forward On-Voltage	--	--	1.4	V	I _S =9A , V _{GS} =0
R _{th(j-c)}	Thermal Resistance, Junction to Case	--	--	4.5	C/ W	

Note 1: Repetitive Rating : Pulse width limited by maximum junction temperature

Note 2: Pulse test: PW ≤ 300us , duty cycle ≤ 2%.

Ratings and Characteristic curves

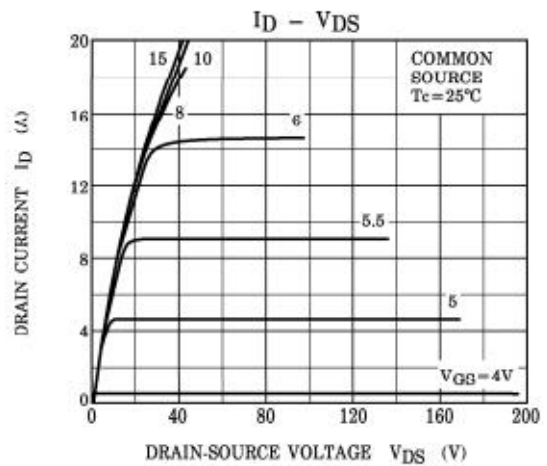
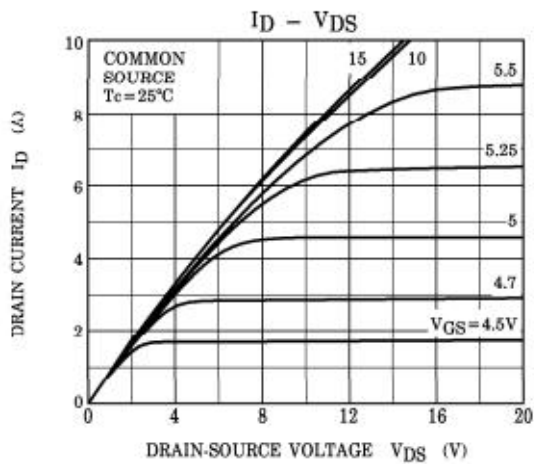
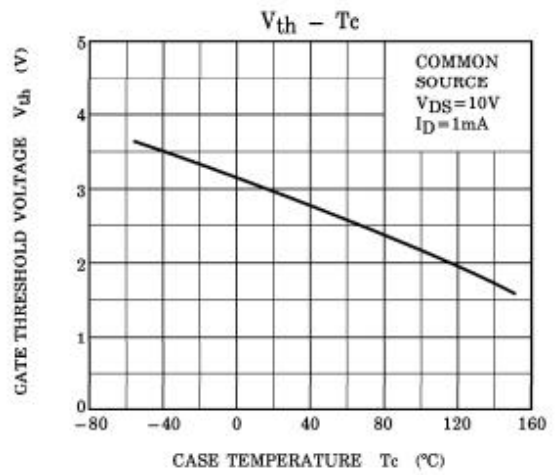
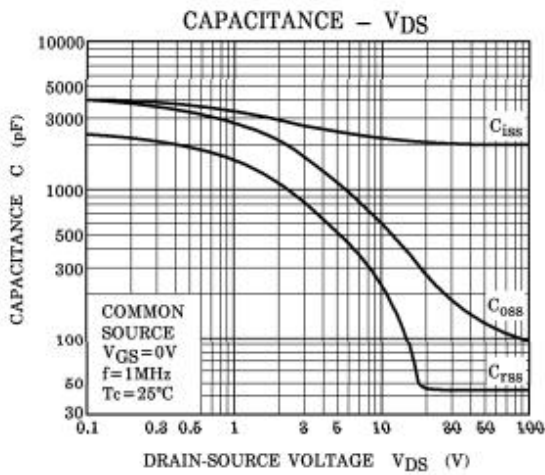
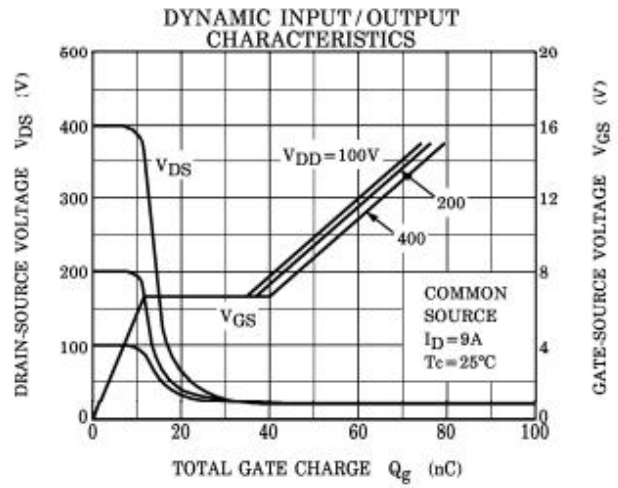
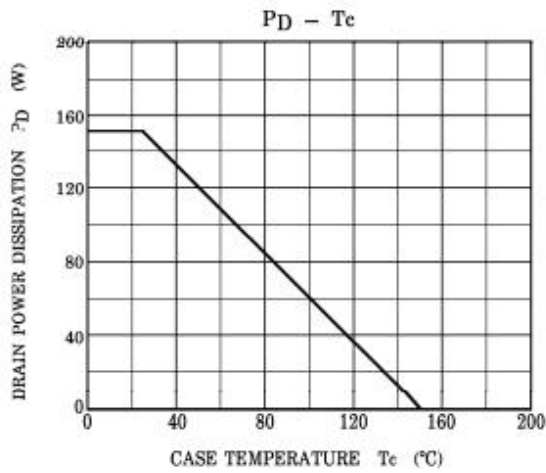

■ **TEST CIRCUITS AND WAVEFORMS**

Gate Charge Test Circuit

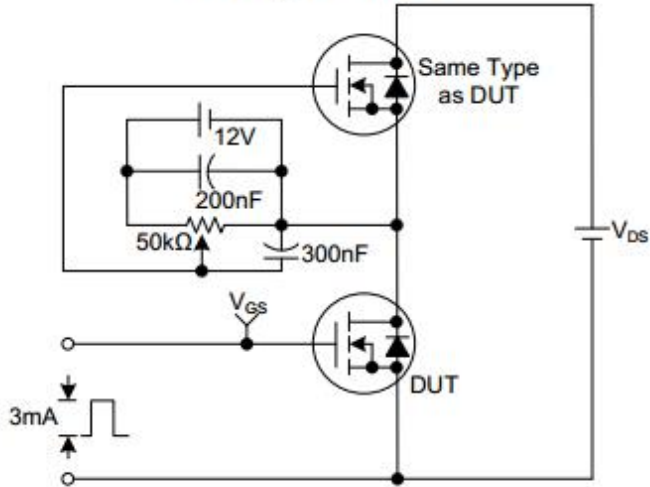

Gate Charge Waveforms

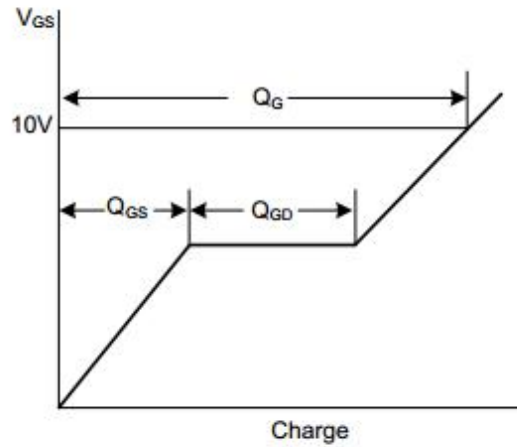

Unclamped Inductive Switching Test Circuit

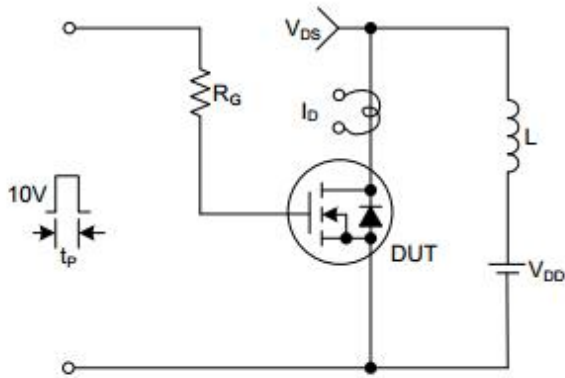

Unclamped Inductive Switching Waveforms

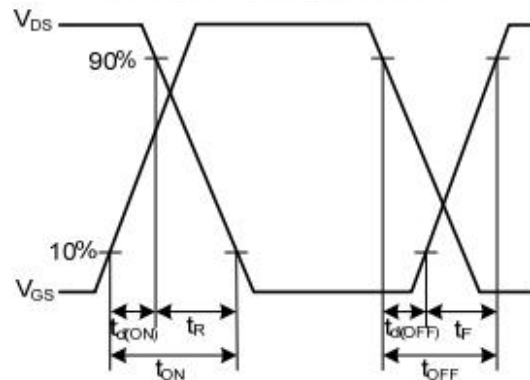
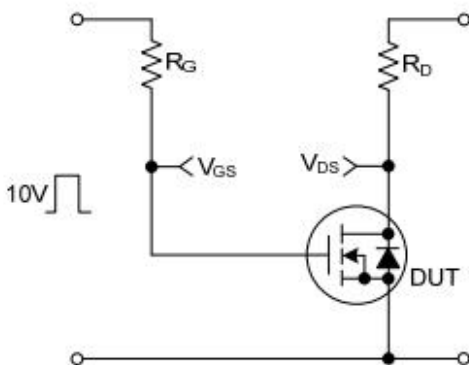
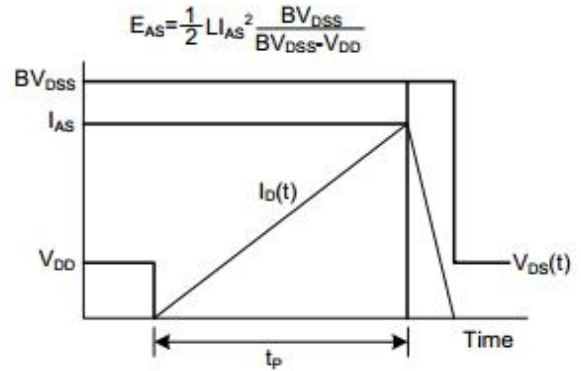

Package Mechanical Data-TO-220F Single

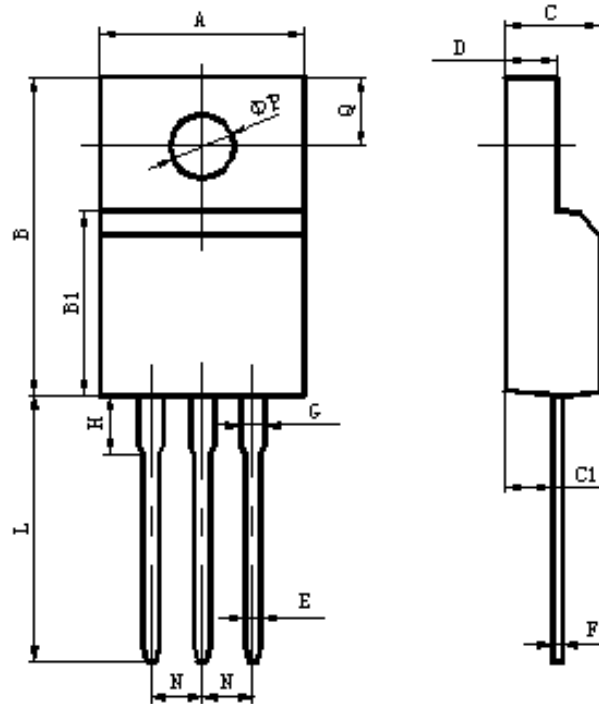

Items	Values(mm)	
	MIN	MAX
A	9.60	10.4
B	15.4	16.2
B1	8.90	9.50
C	4.30	4.90
C1	2.10	3.00
D	2.40	3.00
E	0.60	1.00
F	0.30	0.60
G	1.12	1.42
H	3.40	3.80
	2.40	2.90
L*	12.0	14.0
N	2.34	2.74
Q	3.15	3.55
ϕP	2.90	3.30