

General Description

The MY15N60F is silicon N-channel Enhanced VDMOSFETS, obtained by the self-aligned planar Technology which reduce the conduction loss, improve switching performance and enhance the avalanche energy.



Features

V_{DSS}	600	V
I_D	15	A
P_D ($T_C = 25^\circ\text{C}$)	52	W
$R_{DS(ON)}$ (at $V_{GS} = 10\text{V}$)	0.23	Ω

Application

- High efficiency switch mode power supplies
- Power factor correction
- Electronic lamp ballast

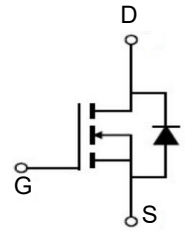
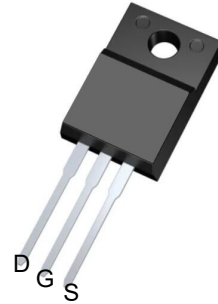

Package Marking and Ordering Information

Product ID	Pack	Marking	Qty(PCS)
MY15N60F	TO-220F	MY15N60F	1000

Absolute Maximum Ratings ($T_C = 25^\circ\text{C}$ unless otherwise noted)

Symbol	Parameters	Ratings	Unit
V_{DSS}	Drain-Source Voltage	600	V
V_{GS}	Gate-Source Voltage-Continuous	± 30	V
I_D	Drain Current-Continuous (Note 2)	15	A
I_{DM}	Drain Current-Single Plused (Note 1)	62	A
P_D	Power Dissipation (Note 2)	52	W
T_j	Max.Operating junction temperature	150	$^\circ\text{C}/\text{W}$

Electrical Characteristics (T_c=25 °C, unless otherwise noted)

Symbol	Parameters	Min	Typ	Max	Units	Conditions
Static Characteristics						
B _{VDSS}	Drain-Source Breakdown VoltageCurrent (Note 1)	600	--	--	mA	I _D =250μA V _{GS} =0V, T _J =25°C
V _{GS(th)}	Gate Threshold Voltage	2.0	--	4.0	V	V _{DS} =V _{GS} , I _D =250μA
R _{DS(on)}	Drain-Source On-Resistance	--	0.23	0.65	Ω	V _{GS} =10V, I _D =7.5A
I _{GSS}	Gate-Body Leakage Current	--	--	±100	nA	V _{GS} =±30V, V _{DS} =0
I _{DSS}	Zero Gate Voltage Drain Current	--	--	1	μA	V _{DS} =600V, V _{GS} =0
g _{fs}	Forward Transconductance	--	4.0	--	S	V _{DS} =40V, I _D =7.5A
Switching Characteristics						
T _{d(on)}	Turn-On Delay Time	--	10	--	ns	V _{DS} =250V, I _D =8A, R _G =25Ω (Note 2)
T _r	Rise Time	--	5	--	ns	
T _{d(off)}	Turn-Off Delay Time	--	55	75	ns	
T _f	Fall Time	--	4.5	10	ns	
Q _g	Total Gate Charge	--	29	45	nC	V _{DS} =480V, V _{GS} =10V I _D =15A (Note 2)
Q _{gs}	Gate-Source Charge	--	6.5	--	nC	
Q _{gd}	Gate-Drain Charge	--	12.5	--	nC	
Dynamic Characteristics						
C _{iss}	Input Capacitance	--	1360	--	pF	V _{DS} =25V, V _{GS} =0, f=1MHz
C _{oss}	Output Capacitance	--	115	--	pF	
C _{rss}	Reverse Transfer Capacitance	--	4.8	--	pF	
I _S	Continuous Drain-Source Diode Forward Current (Note 2)	--	--	15	A	
V _{SD}	Diode Forward On-Voltage	--	--	1.3	V	I _S =15A, V _{GS} =0
R _{th(j-c)}	Thermal Resistance, Junction to Case	--	--	3.65	°C/W	

Note 1: Repetitive Rating : Pulse width limited by maximum junction temperature

Note 2: Pulse test: PW ≤ 300us, duty cycle ≤ 2%.

Ratings and Characteristic curves

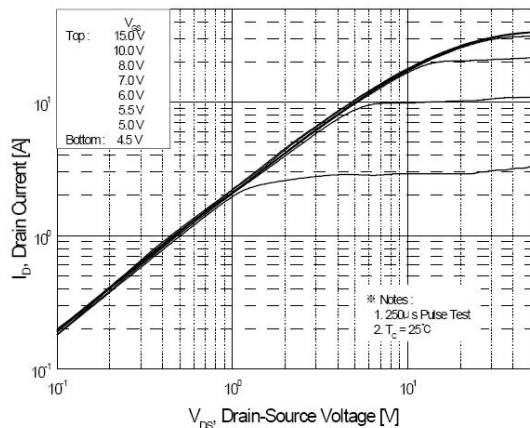

Figure 1. On-Region Characteristics

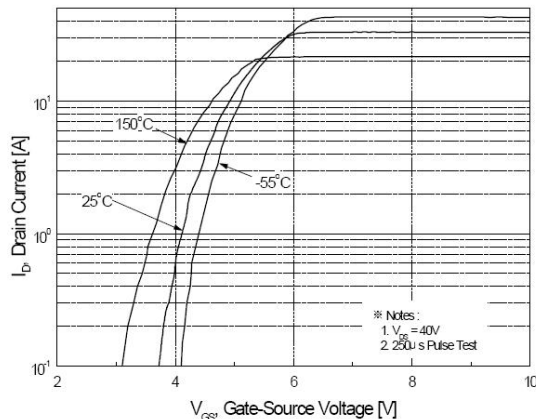

Figure 2. Transfer Characteristics

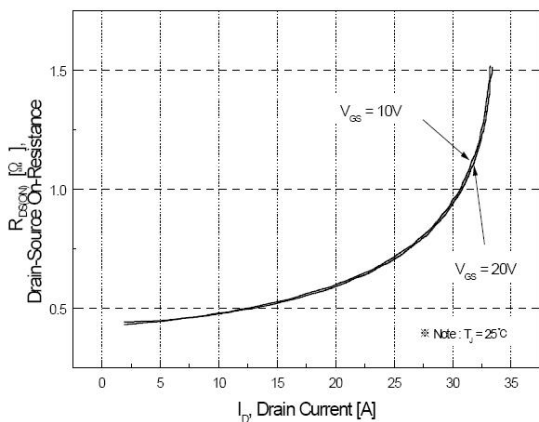

Figure 3. On-Resistance Variation vs Drain Current and Gate Voltage

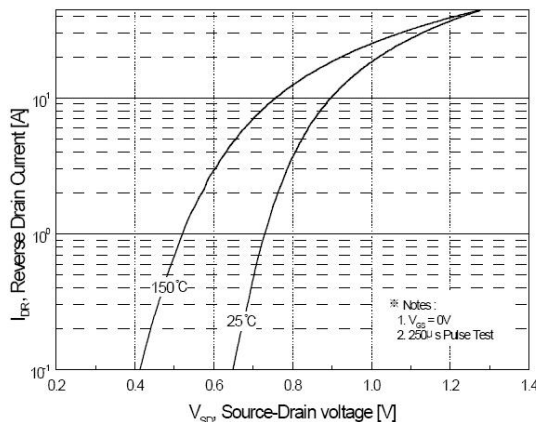

Figure 4. Body Diode Forward Voltage Variation with Source Current and Temperature

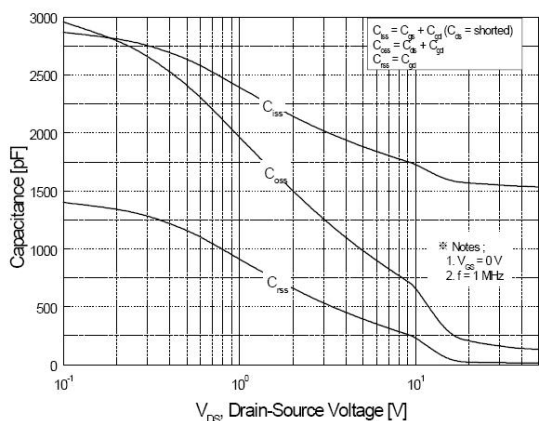

Figure 5. Capacitance Characteristics

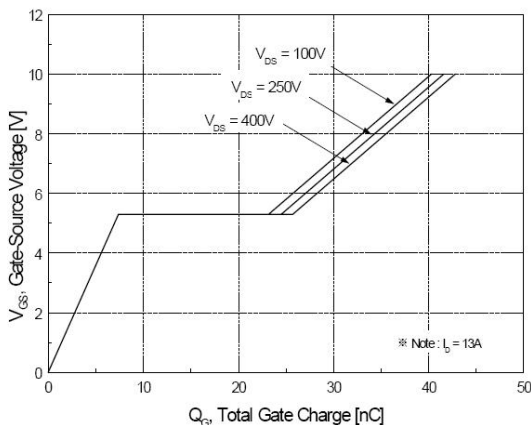

Figure 6. Gate Charge Characteristics

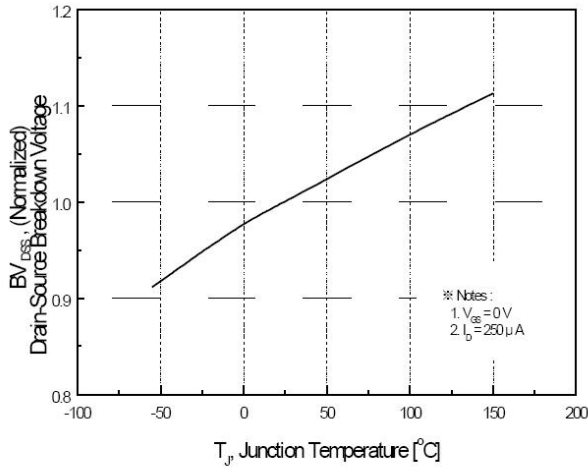

Figure 7. Breakdown Voltage Variation vs Temperature

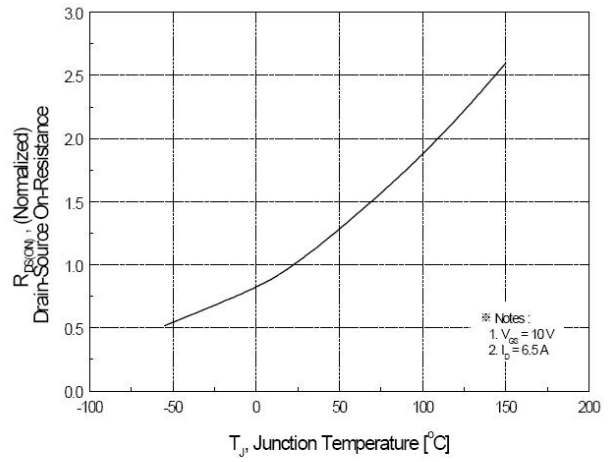

Figure 8. On-Resistance Variation vs Temperature

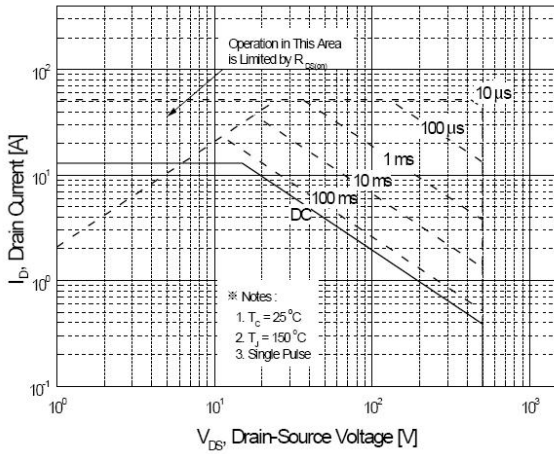

Figure 9. Maximum Safe Operating Area

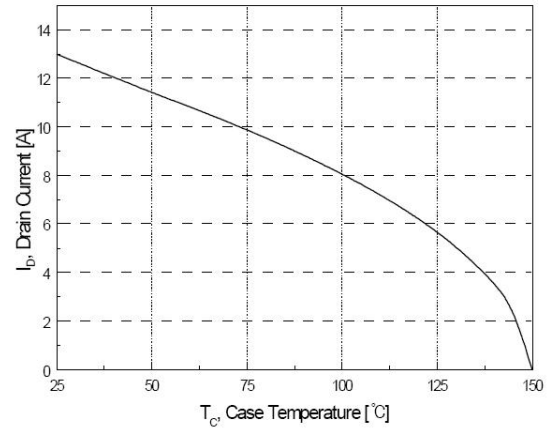

Figure 10. Maximum Drain Current vs Case Temperature

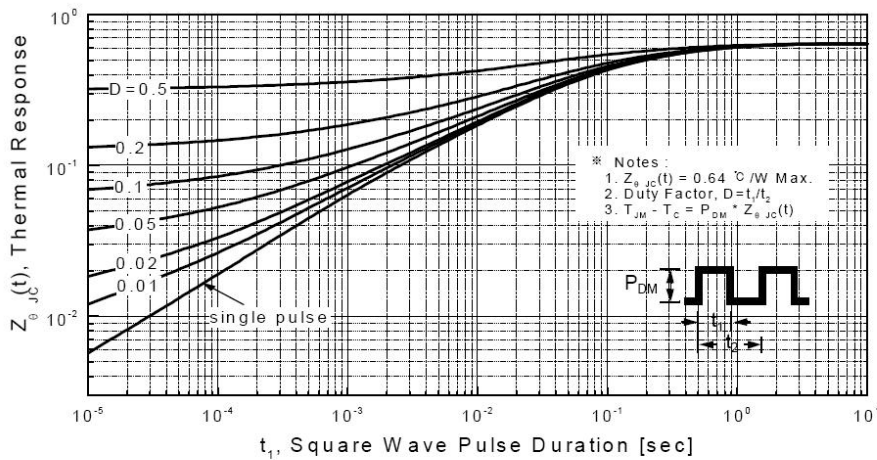

Figure 11. Transient Thermal Response Curve

Fig 12. Gate Charge Test Circuit & Waveform

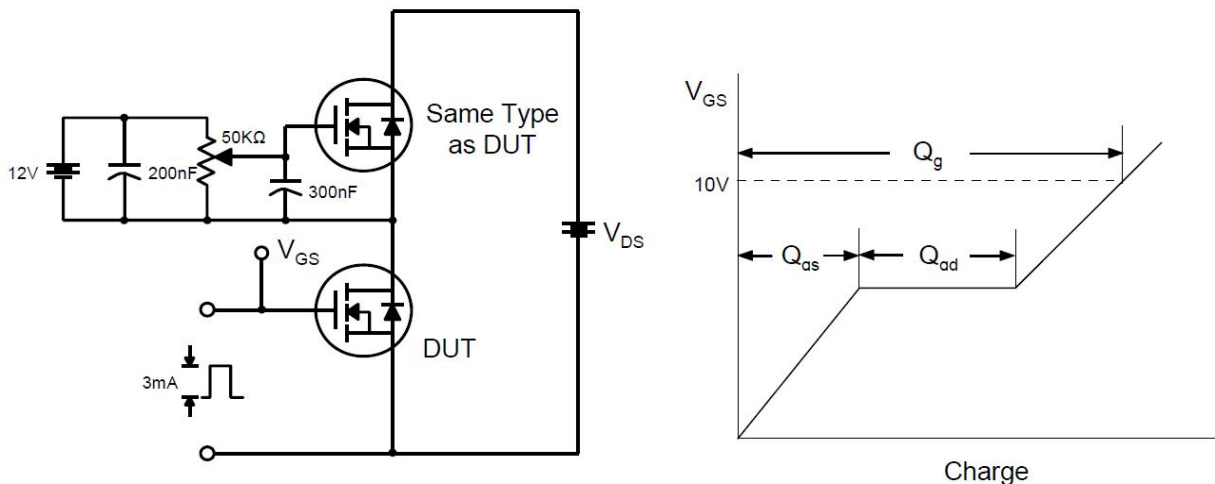

Fig 13. Resistive Switching Test Circuit & Waveforms

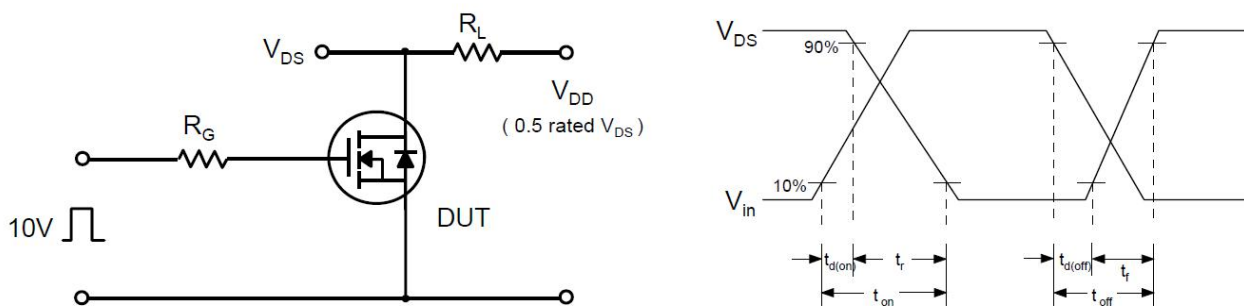

Fig 14. Unclamped Inductive Switching Test Circuit & Waveforms

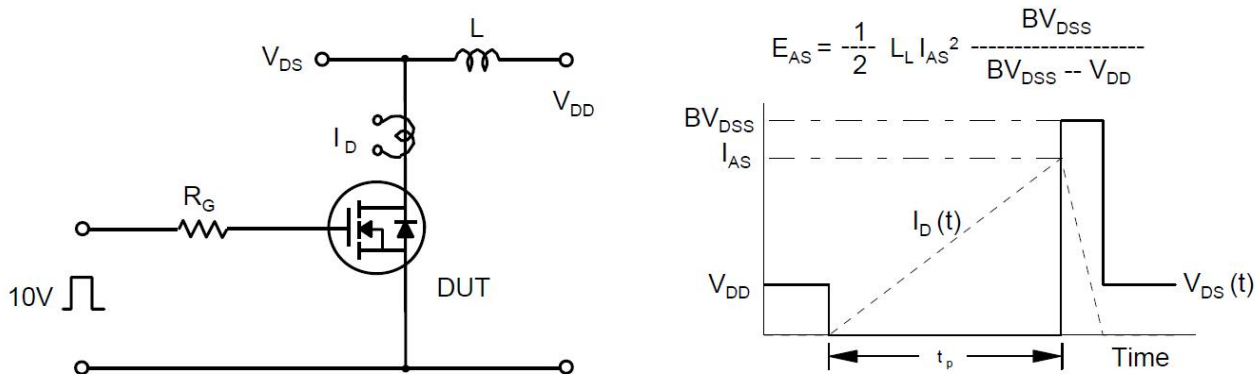
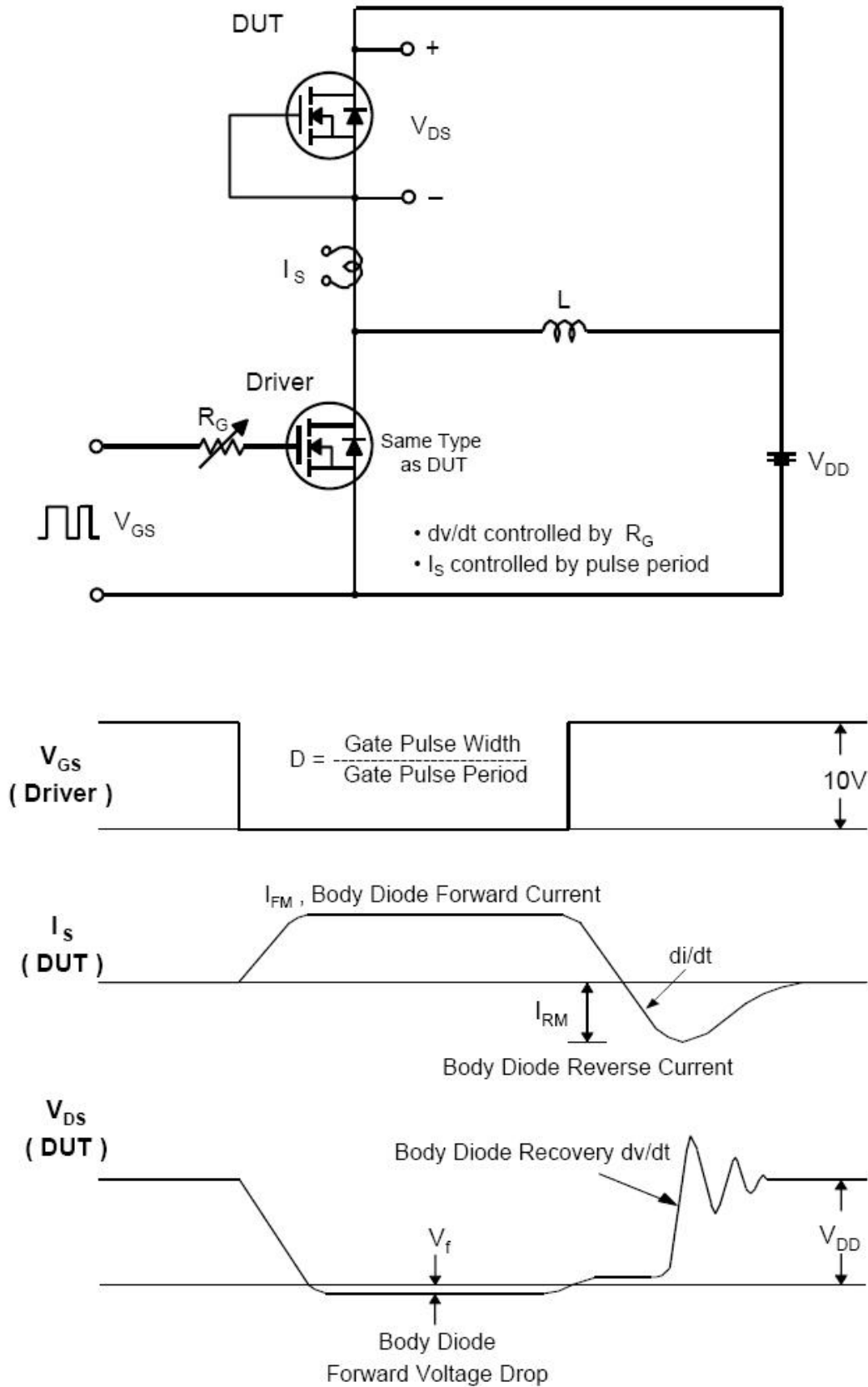
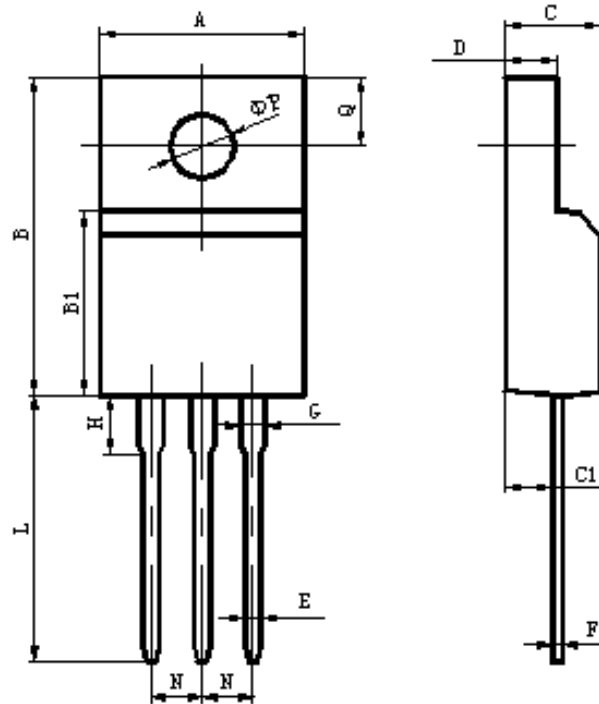

Fig 15. Peak Diode Recovery dv/dt Test Circuit & Waveforms



Package Mechanical Data-TO-220F Single



Items	Values(mm)	
	MIN	MAX
A	9.60	10.4
B	15.4	16.2
B1	8.90	9.50
C	4.30	4.90
C1	2.10	3.00
D	2.40	3.00
E	0.60	1.00
F	0.30	0.60
G	1.12	1.42
H	3.40	3.80
	2.40	2.90
L*	12.0	14.0
N	2.34	2.74
Q	3.15	3.55
φ P	2.90	3.30