

## General Description

The MY10N60F is silicon N-channel Enhanced VDMOSFETs, obtained by the self-aligned planar Technology which reduce the conduction loss, improve switching performance and enhance the avalanche energy.

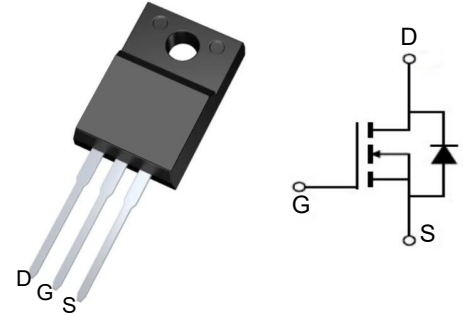


## Features

$V_{DSS}$	600	V
$I_D$	10	A
$P_D(T_C=25\text{C})$	48	W
$R_{DS(ON)}(at\ V_{GS} = 10V)$	1	$\Omega$

## Application

- Fast Switching
- Low ON Resistance
- Low Gate Charge
- Power factor correction



## Package Marking and Ordering Information

Product ID	Pack	Marking	Qty(PCS)
MY10N60F	TO-220F	MY10N60F	1000

## Absolute Maximum Ratings ( $T_c=25\text{ }^\circ\text{C}$ unless otherwise noted)

Symbol	Parameters	Ratings	Unit
$V_{DSS}$	Drain-Source Voltage	600	V
$V_{GS}$	Gate-Source Voltage-Continuous	$\pm 30$	V
$I_D$	Drain Current-Continuous (Note 2)	10	A
$I_{DM}$	Drain Current-Single Plused (Note 1)	36	A
$P_D$	Power Dissipation (Note 2)	48	W
$T_j$	Max.Operating junction temperature	150	$^\circ\text{C/W}$

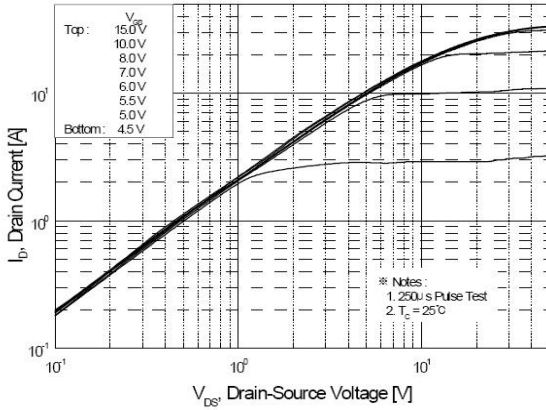
**Electrical Characteristics (T<sub>c</sub>=25 °C, unless otherwise noted)**

Symbol	Parameters	Min	Typ	Max	Units	Conditions
<b>Static Characteristics</b>						
B <sub>VDSS</sub>	Drain-Source Breakdown VoltageCurrent (Note 1)	600	--	--	mA	I <sub>D</sub> =250μA V <sub>GS</sub> =0V, T <sub>J</sub> =25°C
V <sub>GS(th)</sub>	Gate Threshold Voltage	2.0	--	4.0	V	V <sub>DS</sub> =V <sub>GS</sub> , I <sub>D</sub> =250μA
R <sub>DS(on)</sub>	Drain-Source On-Resistance	--	1	1.2	Ω	V <sub>GS</sub> =10V, I <sub>D</sub> =4A
I <sub>GSS</sub>	Gate-Body Leakage Current	--	--	±100	nA	V <sub>GS</sub> =±30V, V <sub>DS</sub> =0
I <sub>DSS</sub>	Zero Gate Voltage Drain Current	--	--	1	μA	V <sub>DS</sub> =650V, V <sub>GS</sub> =0
<b>Switching Characteristics</b>						
T <sub>d(on)</sub>	Turn-On Delay Time	--	23	55	ns	V <sub>DS</sub> =325V, I <sub>D</sub> =8A, R <sub>G</sub> =25Ω (Note 2)
T <sub>r</sub>	Rise Time	--	69.5	150	ns	
T <sub>d(off)</sub>	Turn-Off Delay Time	--	144	300	ns	
T <sub>f</sub>	Fall Time	--	77.5	165	ns	
Q <sub>g</sub>	Total Gate Charge	--	44	36	nC	V <sub>DS</sub> =480, V <sub>GS</sub> =1, I <sub>D</sub> =8A (Note 2)
Q <sub>gs</sub>	Gate-Source Charge	--	65	--	nC	
Q <sub>gd</sub>	Gate-Drain Charge	--	19	--	nC	
<b>Dynamic Characteristics</b>						
C <sub>iss</sub>	Input Capacitance	--	1570	2040	pF	V <sub>DS</sub> =25V, V <sub>GS</sub> =0, f=1MHz
C <sub>oss</sub>	Output Capacitance	--	166	2040	pF	
C <sub>rss</sub>	Reverse Transfer Capacitance	--	18	24	pF	
I <sub>S</sub>	Continuous Drain-Source Diode Forward Current (Note 2)	--	--	10	A	
V <sub>SD</sub>	Diode Forward On-Voltage	--	--	1.4	V	I <sub>S</sub> =8A, V <sub>GS</sub> =0
R <sub>th(j-c)</sub>	Thermal Resistance, Junction to Case	--	--	2.6	C/ W	

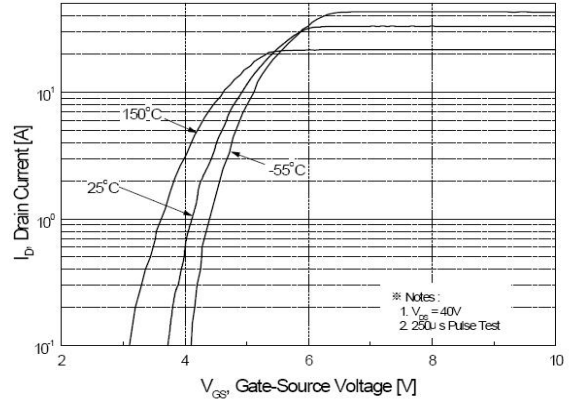
Note 1: Repetitive Rating : Pulse width limited by maximum junction temperature

Note 2: Pulse test: PW ≤ 300us, duty cycle ≤ 2%.

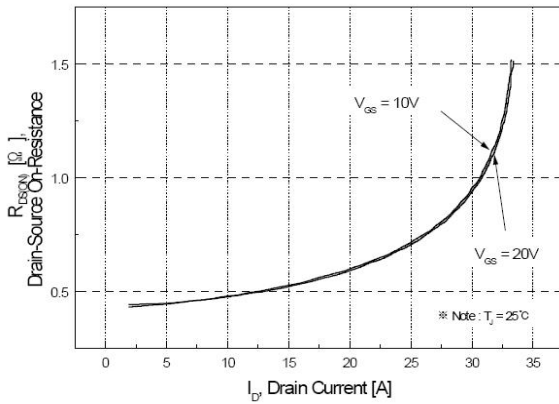
**Typical Characteristics**



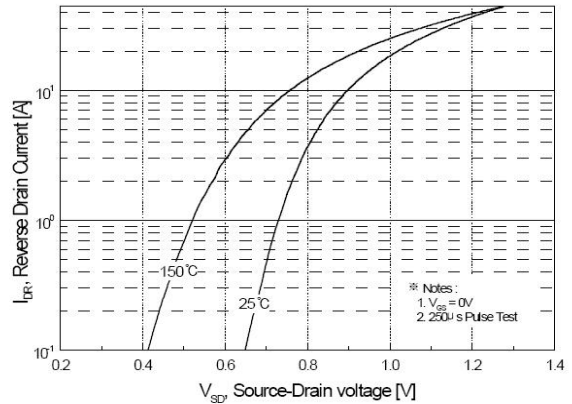
**Figure 1. On-Region Characteristics**



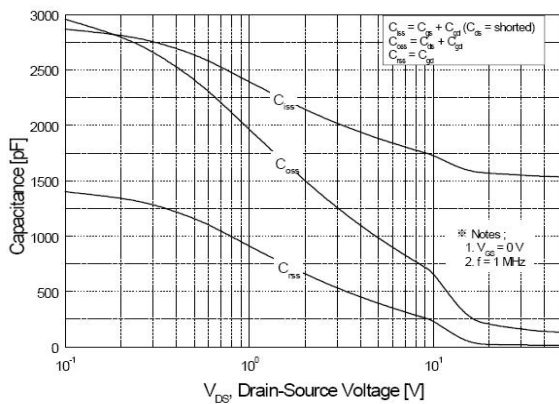
**Figure 2. Transfer Characteristics**



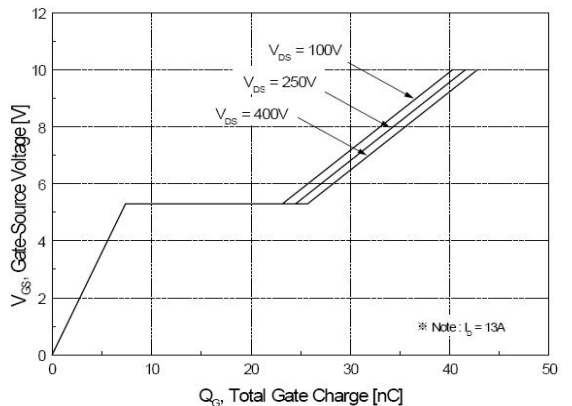
**Figure 3. On-Resistance Variation vs Drain Current and Gate Voltage**



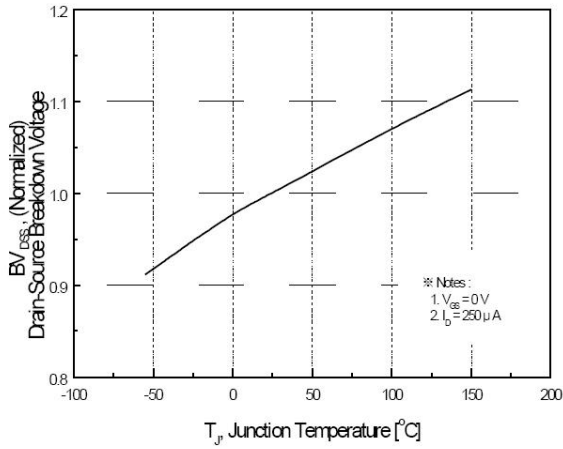
**Figure 4. Body Diode Forward Voltage Variation with Source Current and Temperature**



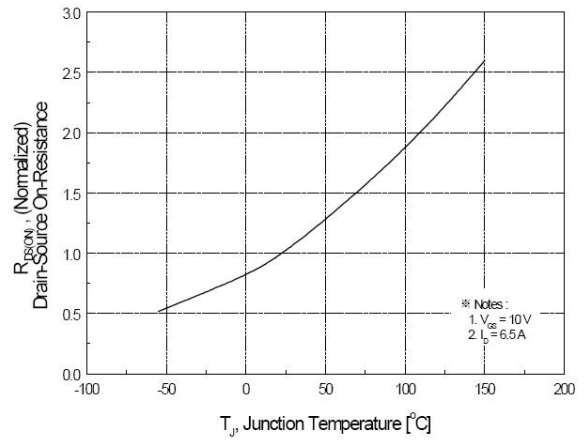
**Figure 5. Capacitance Characteristics**



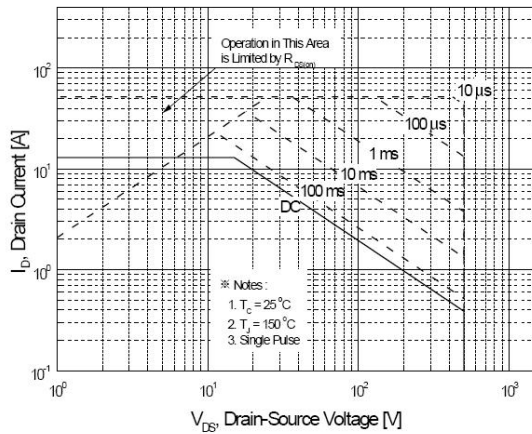
**Figure 6. Gate Charge Characteristics**



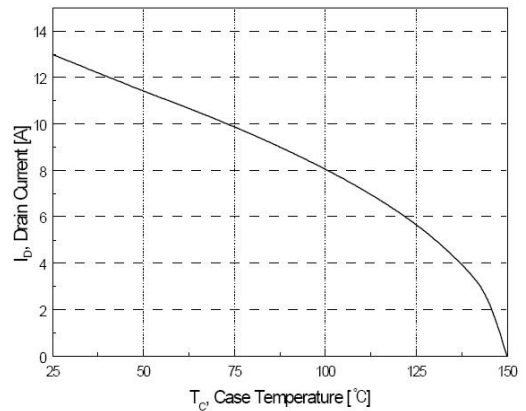
**Figure 7. Breakdown Voltage Variation vs Temperature**



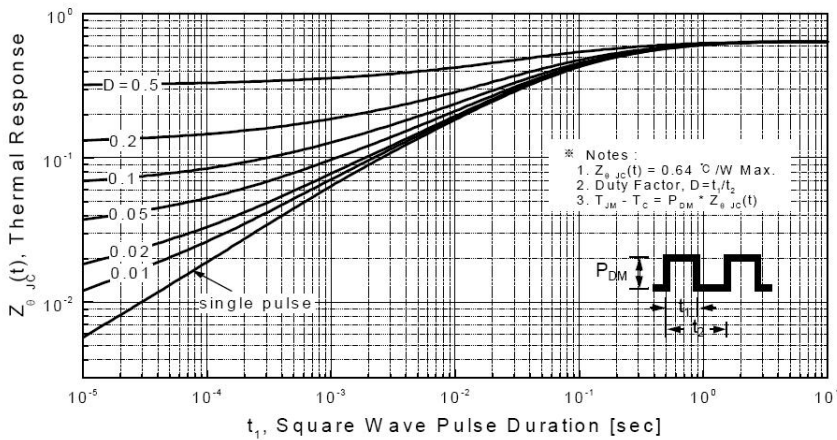
**Figure 8. On-Resistance Variation vs Temperature**



**Figure 9. Maximum Safe Operating Area**

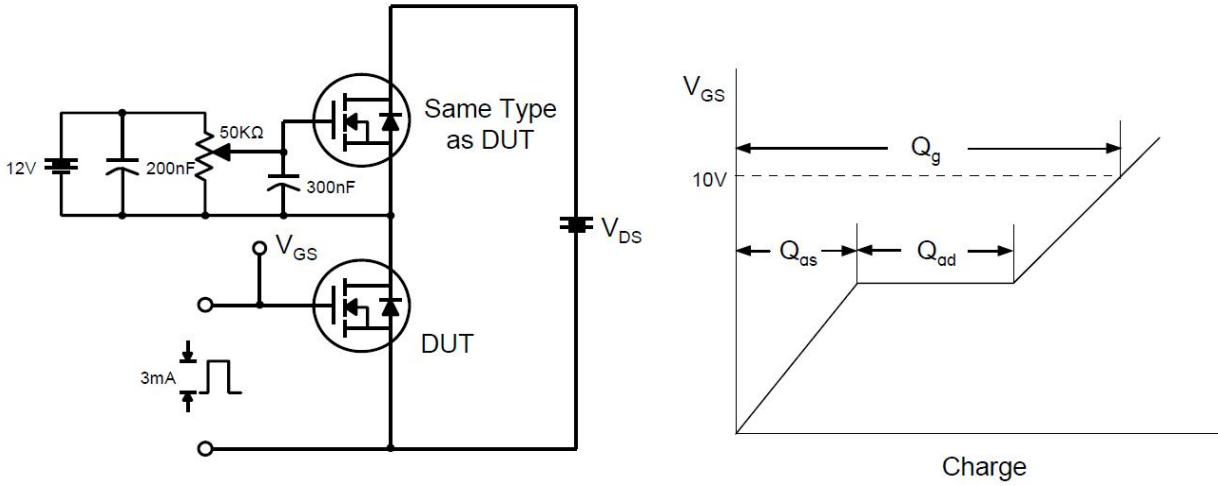


**Figure 10. Maximum Drain Current vs Case Temperature**

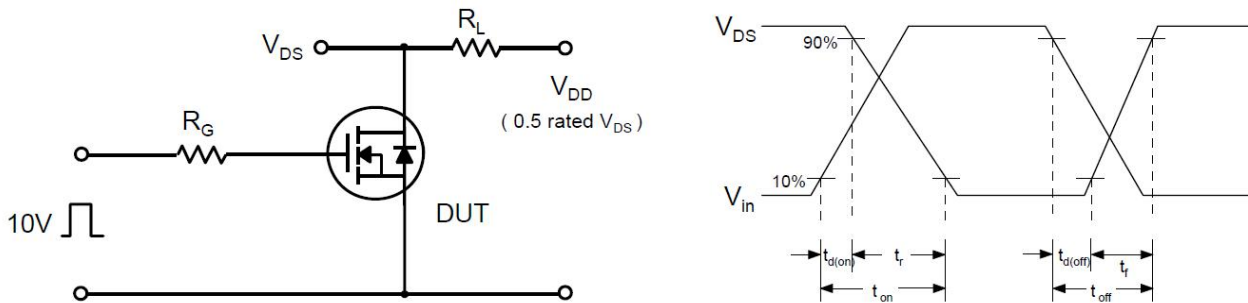


**Figure 11. Transient Thermal Response Curve**

**Fig 12. Gate Charge Test Circuit & Waveform**



**Fig 13. Resistive Switching Test Circuit & Waveforms**



**Fig 14. Unclamped Inductive Switching Test Circuit & Waveforms**

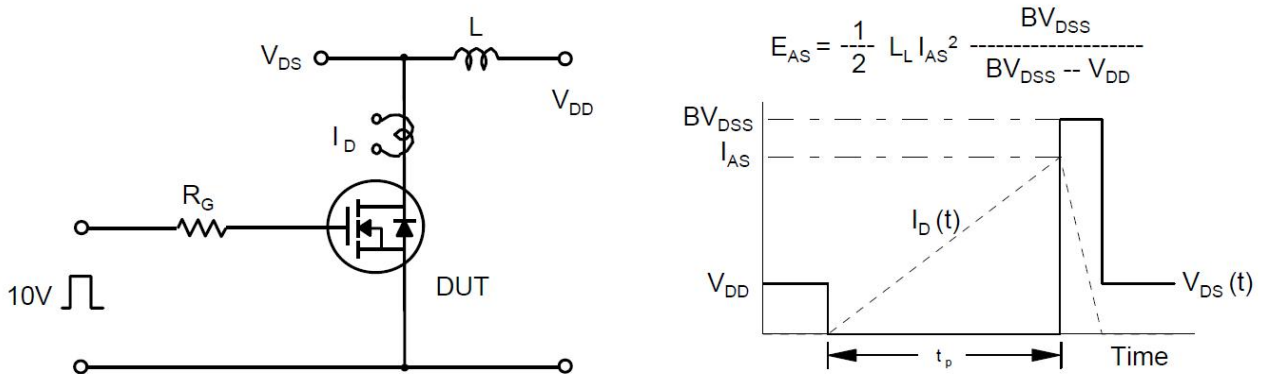


Fig 15. Peak Diode Recovery dv/dt Test Circuit & Waveforms

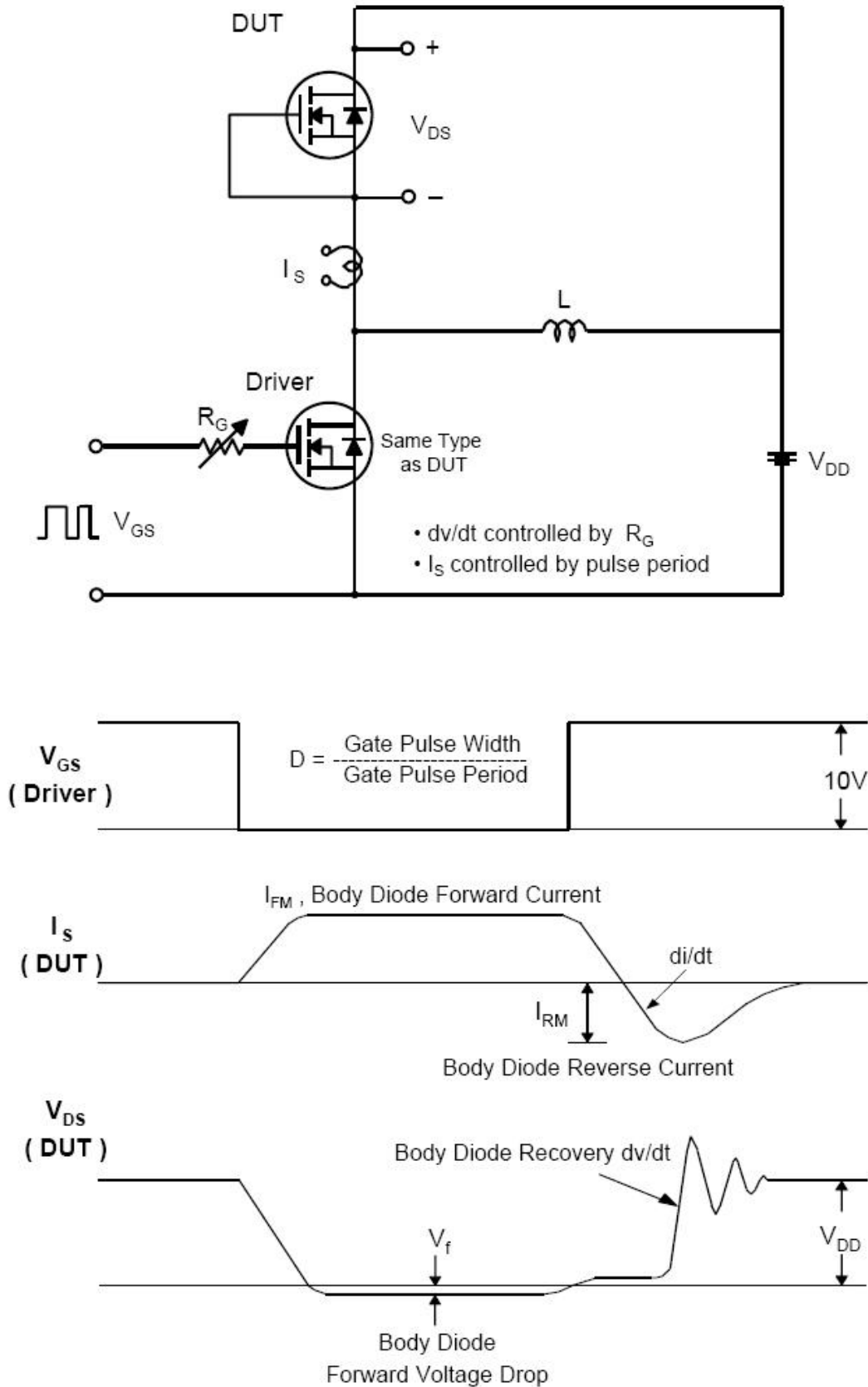
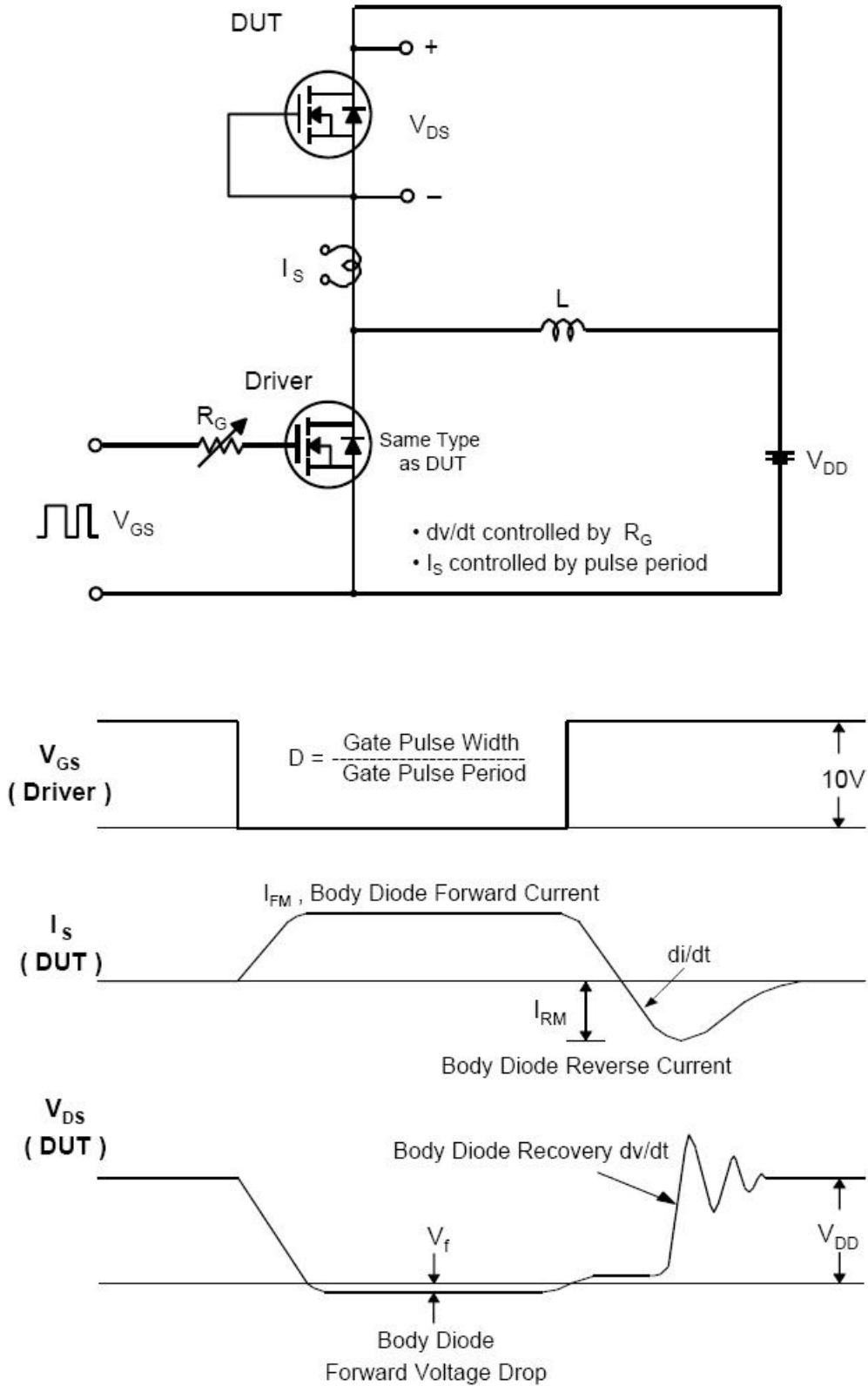
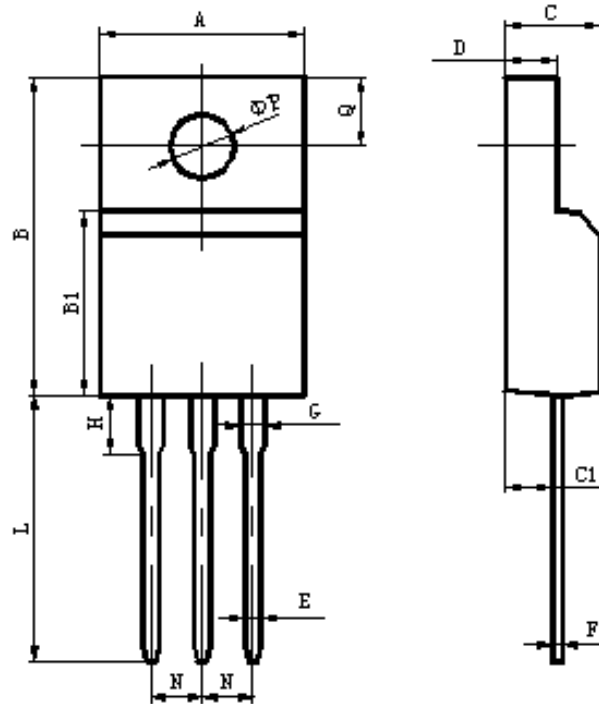


Fig 15. Peak Diode Recovery dv/dt Test Circuit & Waveforms



**Package Mechanical Data-TO-220F Single**



Items	Values(mm)	
	MIN	MAX
A	9.60	10.4
B	15.4	16.2
B1	8.90	9.50
C	4.30	4.90
C1	2.10	3.00
D	2.40	3.00
E	0.60	1.00
F	0.30	0.60
G	1.12	1.42
H	3.40	3.80
	2.40	2.90
L*	12.0	14.0
N	2.34	2.74
Q	3.15	3.55
$\phi P$	2.90	3.30