

## General Description

The MY016CNE5 uses Fast switching MOSFET for SMPS Very low on-resistance RDS(on) and Optimized technology for DC/DC converters.



## Features

V <sub>DSS</sub>	30	V
I <sub>D</sub>	100	A
P <sub>D</sub> (T <sub>C</sub> =25 °C)	139	W
R <sub>DS(ON)</sub> (at V <sub>GS</sub> =10V)	1.6	mΩ

## Application

- logic level
- Superior thermal resistance
- 100 valanche tested
- P-free plating

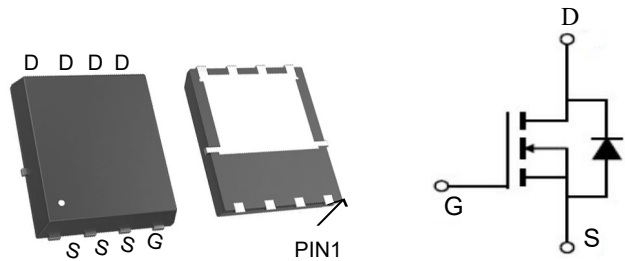

## Package Marking and Ordering Information

Product ID	Pack	Marking	Qty(PCS)
MY016CNE5	PDFN5*6-8L	NULL	5000

## Absolute Maximum Ratings (T<sub>J</sub>=25 °C unless otherwise noted)

Parameter	Symbol	Conditions	Value	Unit
Continuous drain current	I <sub>D</sub>	V <sub>GS</sub> =10 V, T <sub>C</sub> =25 °C	100	A
		V <sub>GS</sub> =10 V, T <sub>C</sub> =100 °C	100	
		V <sub>GS</sub> =4.5 V, T <sub>C</sub> =25 °C	100	
		V <sub>GS</sub> =4.5 V, T <sub>C</sub> =100 °C	100	
		V <sub>GS</sub> =10 V, T <sub>A</sub> =25 °C, R <sub>thJA</sub> =50 K/W <sup>2</sup> )	31	
Pulsed drain current <sup>3)</sup>	I <sub>D,pulse</sub>	T <sub>C</sub> =25 °C	400	
Avalanche current, single pulse <sup>4)</sup>	I <sub>AS</sub>	T <sub>C</sub> =25 °C	50	
Avalanche energy, single pulse	E <sub>AS</sub>	I <sub>D</sub> =50 A, R <sub>GS</sub> =25 Ω	295	mJ
Gate source voltage	V <sub>GS</sub>		±20	V

**Electrical Characteristics ( $T_j=25\text{ }^\circ\text{C}$ , unless otherwise noted)**

Parameter	Symbol	Conditions	Value	Unit
Power dissipation	$P_{\text{tot}}$	$T_C=25\text{ }^\circ\text{C}$	139	W
		$T_A=25\text{ }^\circ\text{C}$ , $R_{\text{thJA}}=50\text{ K/W}^2)$	2.5	
Operating and storage temperature	$T_j, T_{\text{stg}}$		-55 ... 150	$^\circ\text{C}$
IEC climatic category; DIN IEC 68-1			55/150/56	

Parameter	Symbol	Conditions	Values			Unit
			min.	typ.	max.	

**Thermal characteristics**

Thermal resistance, junction - case	$R_{\text{thJC}}$	bottom	-	-	0.9	K/W
		top			20	
Device on PCB	$R_{\text{thJA}}$	6 cm <sup>2</sup> cooling area <sup>2)</sup>	-	-	50	

**Electrical characteristics, at  $T_j=25\text{ }^\circ\text{C}$ , unless otherwise specified**

**Static characteristics**

Drain-source breakdown voltage	$V_{(\text{BR})\text{DSS}}$	$V_{\text{GS}}=0\text{ V}, I_{\text{D}}=1\text{ mA}$	30	-	-	V
Gate threshold voltage	$V_{\text{GS(th)}}$	$V_{\text{DS}}=V_{\text{GS}}, I_{\text{D}}=85\text{ }\mu\text{A}$	1.2	-	2	
Zero gate voltage drain current	$I_{\text{DSS}}$	$V_{\text{DS}}=40\text{ V}, V_{\text{GS}}=0\text{ V}, T_j=25\text{ }^\circ\text{C}$	-	0.1	1	$\mu\text{A}$
		$V_{\text{DS}}=40\text{ V}, V_{\text{GS}}=0\text{ V}, T_j=125\text{ }^\circ\text{C}$	-	10	100	
Gate-source leakage current	$I_{\text{GSS}}$	$V_{\text{GS}}=20\text{ V}, V_{\text{DS}}=0\text{ V}$	-	10	100	nA
Drain-source on-state resistance	$R_{\text{DS(on)}}$	$V_{\text{GS}}=4.5\text{ V}, I_{\text{D}}=50\text{ A}$	-	1.8	2.3	m $\Omega$
		$V_{\text{GS}}=10\text{ V}, I_{\text{D}}=50\text{ A}$	-	1.3	1.6	
Gate resistance	$R_{\text{G}}$		-	1.5	-	$\Omega$
Transconductance	$g_{\text{fs}}$	$ V_{\text{DS}} >2 I_{\text{D}} R_{\text{DS(on)max}}, I_{\text{D}}=50\text{ A}$	95	190	-	S

<sup>2)</sup> Device on 40 mm x 40 mm x 1.5 mm epoxy PCB FR4 with 6 cm<sup>2</sup> (one layer, 70  $\mu\text{m}$  thick) copper area for drain connection. PCB is vertical in still air.

<sup>3)</sup> See figure 3 for more detailed information

<sup>4)</sup> See figure 13 for more detailed information

Parameter	Symbol	Conditions	Values			Unit
			min.	typ.	max.	

**Dynamic characteristics**

Input capacitance	$C_{iss}$	$V_{GS}=0\text{ V}, V_{DS}=20\text{ V}, f=1\text{ MHz}$	-	8900	12000	pF
Output capacitance	$C_{oss}$		-	1800	2400	
Reverse transfer capacitance	$C_{rss}$		-	100	-	
Turn-on delay time	$t_{d(on)}$	$V_{DD}=20\text{ V}, V_{GS}=10\text{ V}, I_D=30\text{ A}, R_G=1.6\ \Omega$	-	14	-	ns
Rise time	$t_r$		-	7.6	-	
Turn-off delay time	$t_{d(off)}$		-	56	-	
Fall time	$t_f$		-	9.4	-	

**Gate Charge Characteristics<sup>5)</sup>**

Gate to source charge	$Q_{gs}$	$V_{DD}=20\text{ V}, I_D=30\text{ A}, V_{GS}=0\text{ to }10\text{ V}$	-	25	-	nC
Gate charge at threshold	$Q_{g(th)}$		-	14	-	
Gate to drain charge	$Q_{gd}$		-	11	-	
Switching charge	$Q_{sw}$		-	23	-	
Gate charge total	$Q_g$		-	113	150	
Gate plateau voltage	$V_{plateau}$		-	2.9	-	V
Gate charge total	$Q_g$	$V_{DD}=20\text{ V}, I_D=30\text{ A}, V_{GS}=0\text{ to }4.5\text{ V}$	-	54	-	nC
Gate charge total, sync. FET	$Q_{g(sync)}$	$V_{DS}=0.1\text{ V}, V_{GS}=0\text{ to }10\text{ V}$	-	106	-	
Output charge	$Q_{oss}$	$V_{DD}=20\text{ V}, V_{GS}=0\text{ V}$	-	69	-	

**Reverse Diode**

Diode continuous forward current	$I_S$	$T_C=25\text{ }^\circ\text{C}$	-	-	100	A
Diode pulse current	$I_{S,pulse}$		-	-	400	
Diode forward voltage	$V_{SD}$	$V_{GS}=0\text{ V}, I_F=50\text{ A}, T_j=25\text{ }^\circ\text{C}$	-	0.8	1.2	V
Reverse recovery charge	$Q_{rr}$	$V_R=20\text{ V}, I_F=I_S, di_F/dt=400\text{ A}/\mu\text{s}$	-	125	-	nC

<sup>5)</sup> See figure 16 for gate charge parameter definition

**1 Power dissipation**

$P_{tot}=f(T_c)$

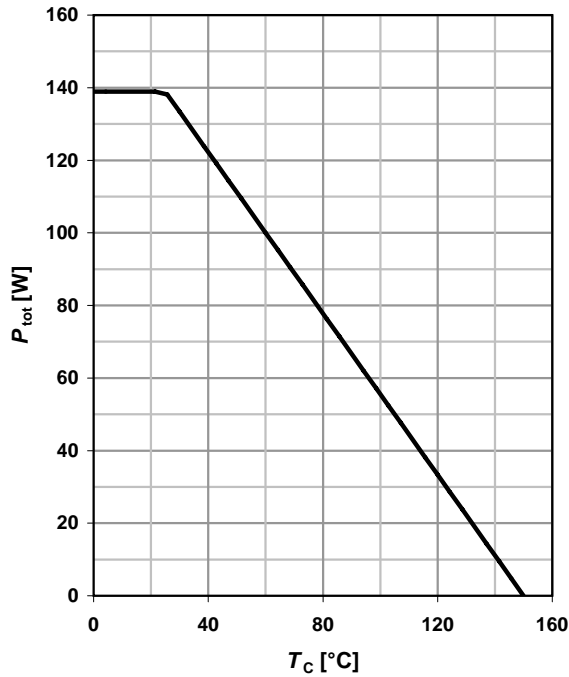

**2 Drain current**

$I_D=f(T_c); V_{GS}\geq 10\text{ V}$

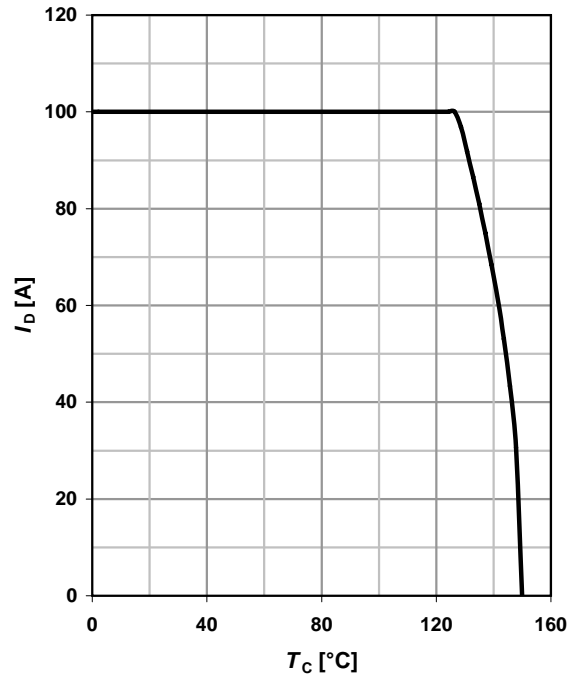

**3 Safe operating area**

$I_D=f(V_{DS}); T_c=25\text{ °C}; D=0$

parameter:  $t_p$

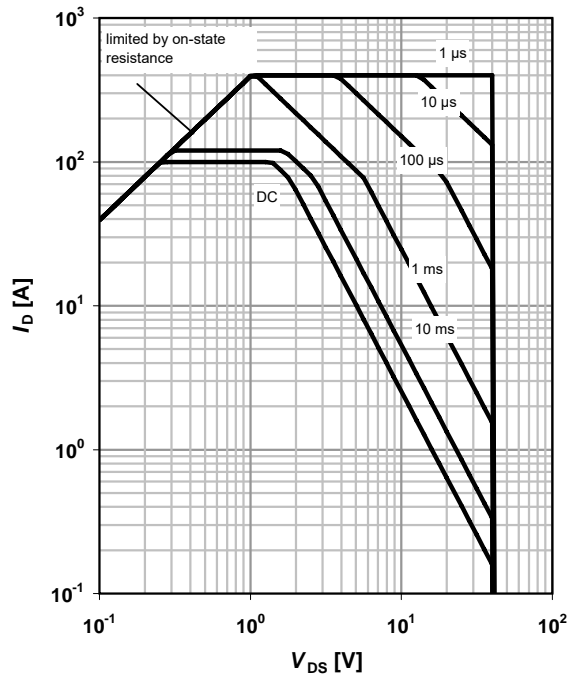

**4 Max. transient thermal impedance**

$Z_{thJC}=f(t_p)$

parameter:  $D=t_p/T$

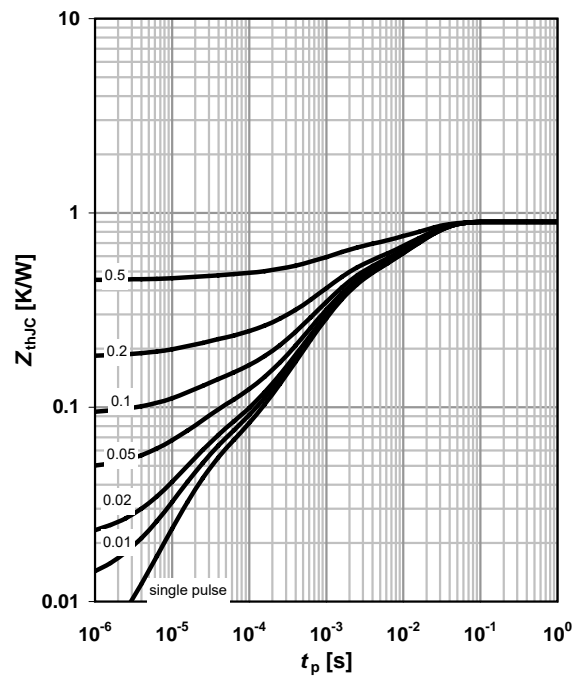

**5 Typ. output characteristics**

$I_D = f(V_{DS}); T_j = 25\text{ }^\circ\text{C}$

parameter:  $V_{GS}$

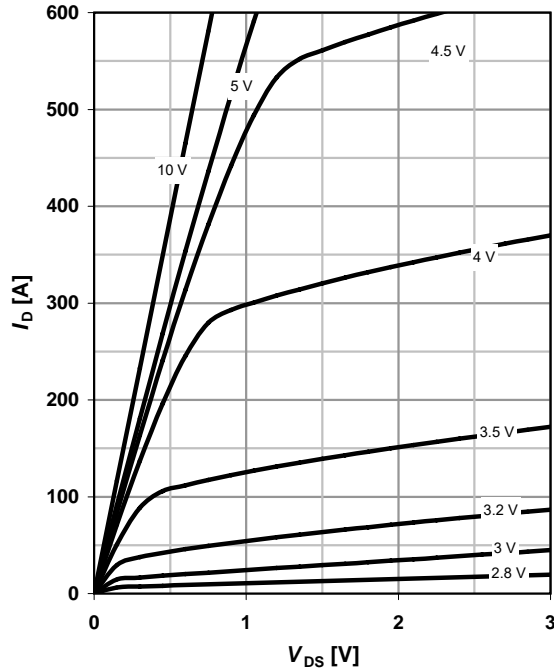

**6 Typ. drain-source on resistance**

$R_{DS(on)} = f(I_D); T_j = 25\text{ }^\circ\text{C}$

parameter:  $V_{GS}$

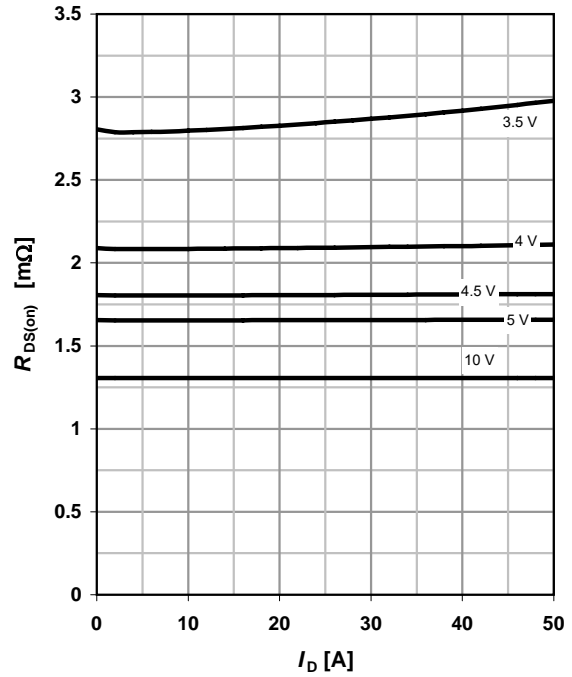

**7 Typ. transfer characteristics**

$I_D = f(V_{GS}); |V_{DS}| > 2|I_D|R_{DS(on)max}$

parameter:  $T_j$

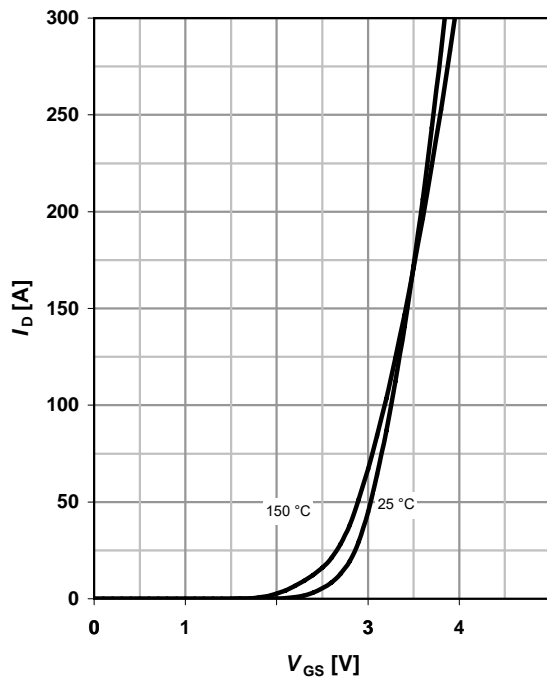

**8 Typ. forward transconductance**

$g_{fs} = f(I_D); T_j = 25\text{ }^\circ\text{C}$

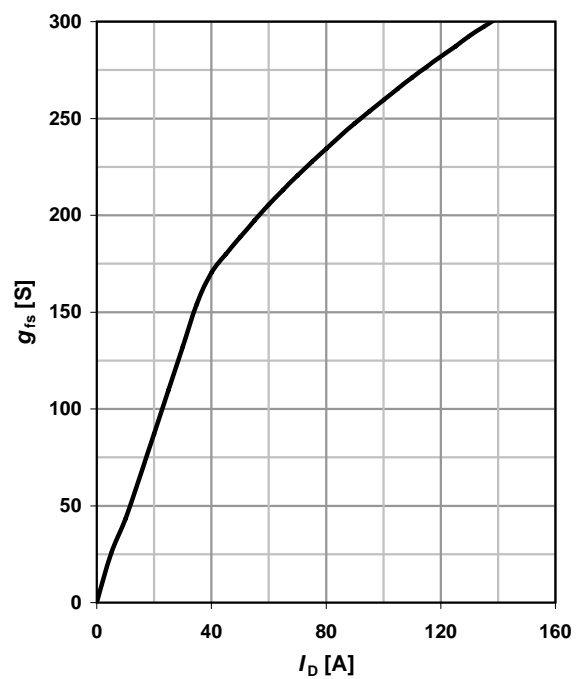

**9 Drain-source on-state resistance**

$R_{DS(on)}=f(T_j); I_D=50\text{ A}; V_{GS}=10\text{ V}$

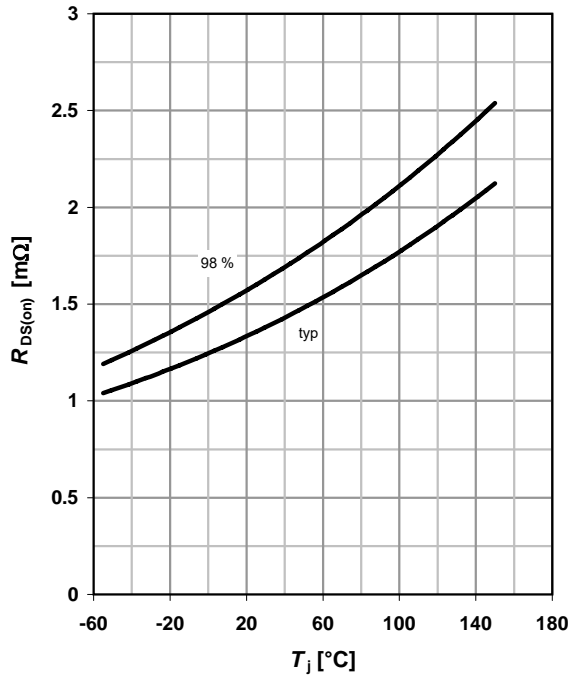

**10 Typ. gate threshold voltage**

$V_{GS(th)}=f(T_j); V_{GS}=V_{DS}; I_D=85\ \mu\text{A}$

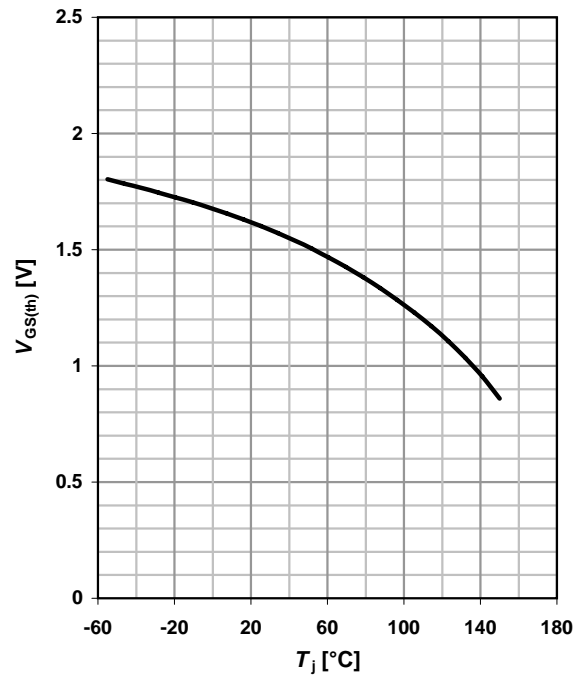

**11 Typ. capacitances**

$C=f(V_{DS}); V_{GS}=0\text{ V}; f=1\text{ MHz}$

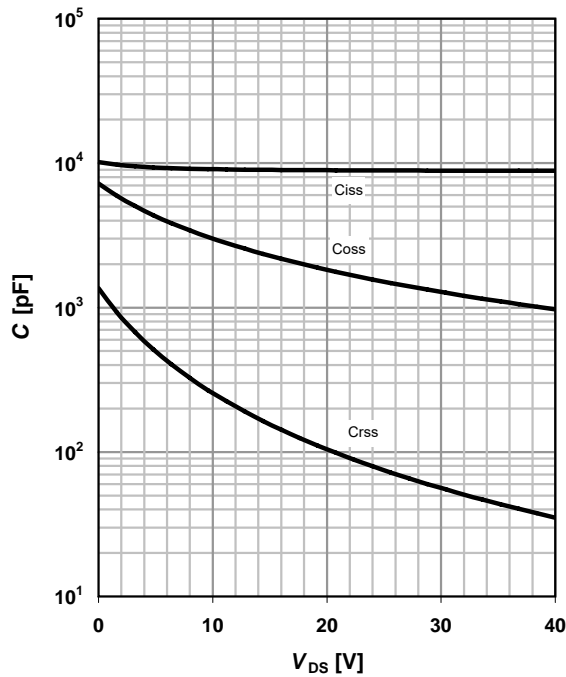

**12 Forward characteristics of reverse diode**

$I_F=f(V_{SD})$

parameter:  $T_j$

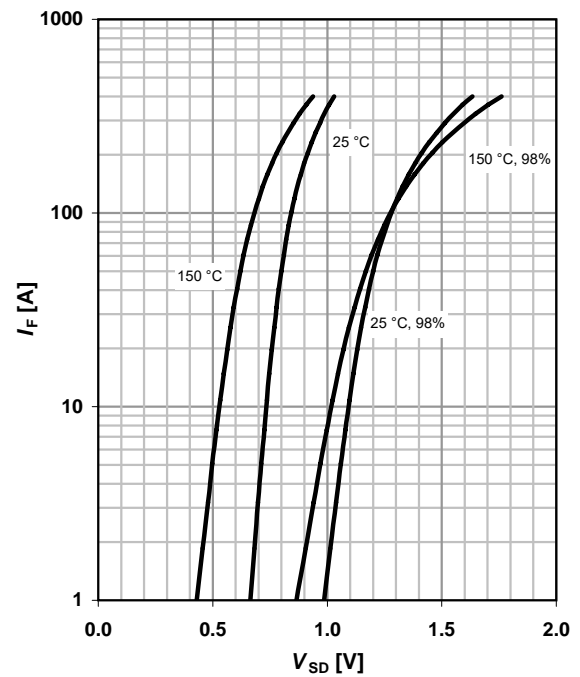

**13 Avalanche characteristics**

$I_{AS}=f(t_{AV}); R_{GS}=25\ \Omega$

parameter:  $T_{j(start)}$

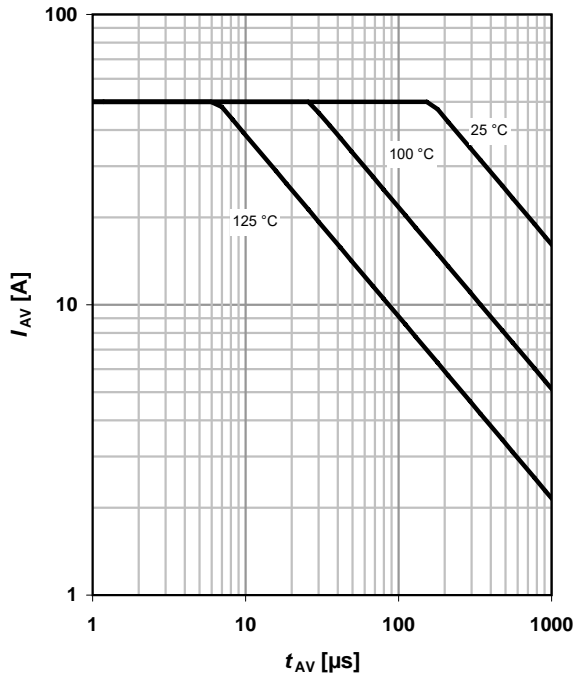

**14 Typ. gate charge**

$V_{GS}=f(Q_{gate}); I_D=30\ \text{A pulsed}$

parameter:  $V_{DD}$

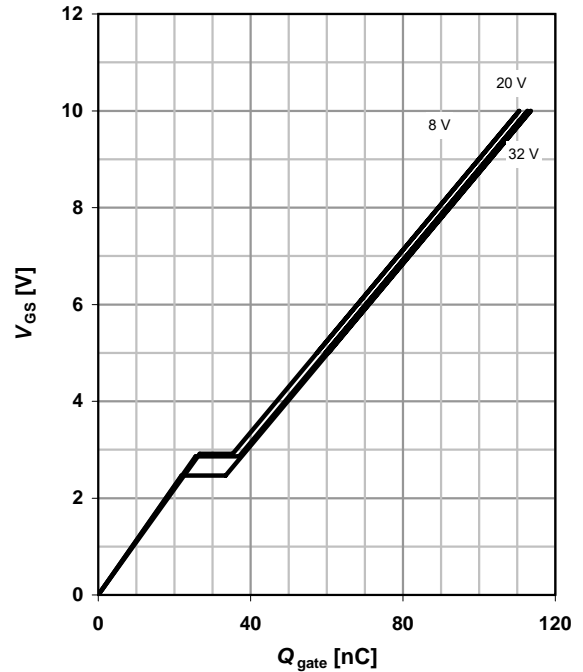

**15 Drain-source breakdown voltage**

$V_{BR(DSS)}=f(T_j); I_D=1\ \text{mA}$

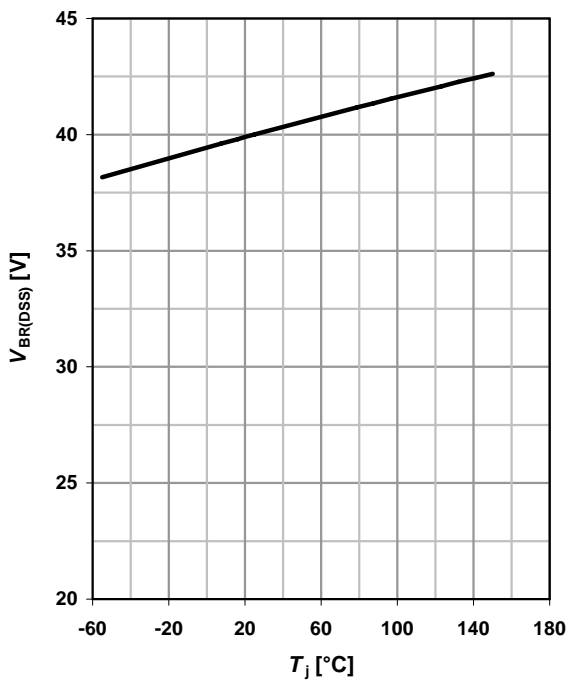

**16 Gate charge waveforms**

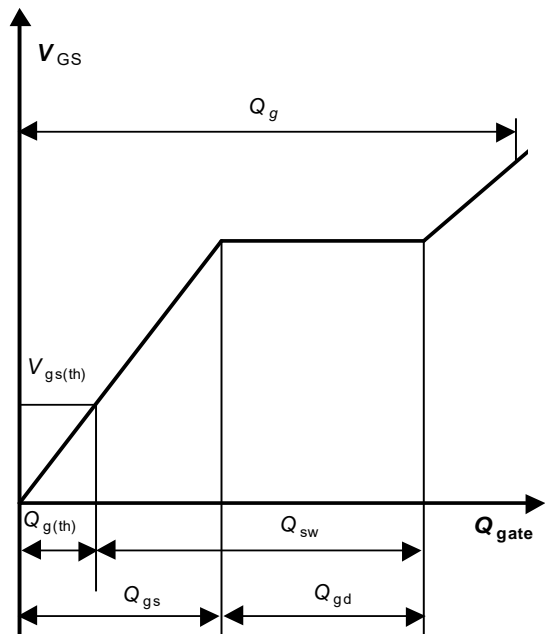

**Package Mechanical Data-DFN5\*6-8L-JQ Single**

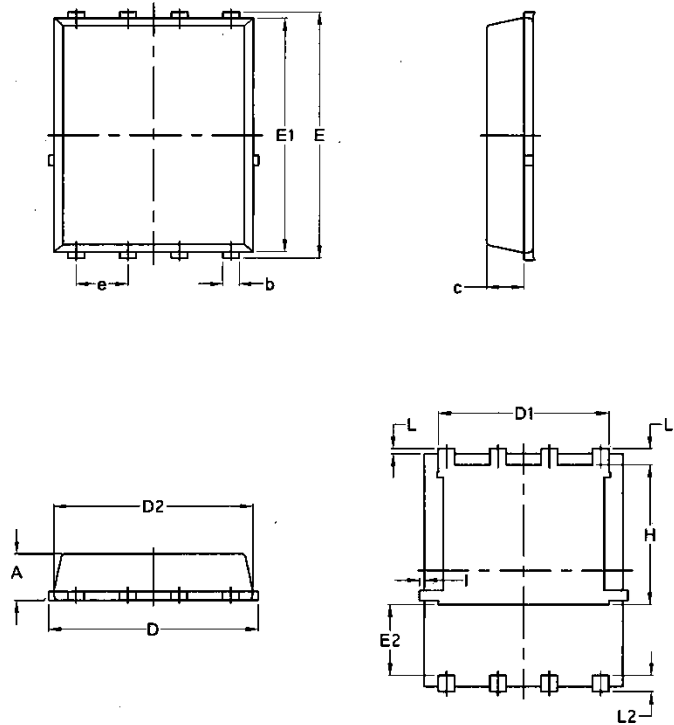

Symbol	Common			
	mm		Inch	
	Min	Max	Min	Max
A	1.03	1.17	0.0406	0.0461
b	0.34	0.48	0.0134	0.0189
c	0.824	0.0970	0.0324	0.082
D	4.80	5.40	0.1890	0.2126
D1	4.11	4.31	0.1618	0.1697
D2	4.80	5.00	0.1890	0.1969
E	5.95	6.15	0.2343	0.2421
E1	5.65	5.85	0.2224	0.2303
E2	1.60	/	0.0630	/
e	1.27 BSC		0.05 BSC	
L	0.05	0.25	0.0020	0.0098
L1	0.38	0.50	0.0150	0.0197
L2	0.38	0.50	0.0150	0.0197
H	3.30	3.50	0.1299	0.1378
I	/	0.18	/	0.0070